

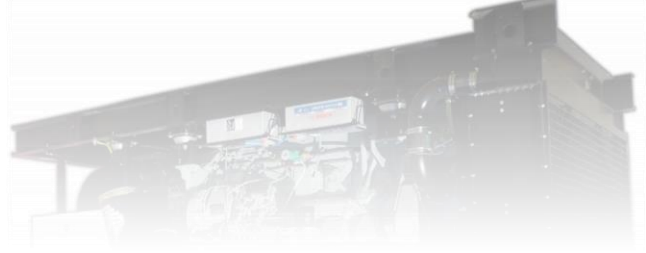

www.tts-martin.sk

MARTIN POWER MP 1750 M

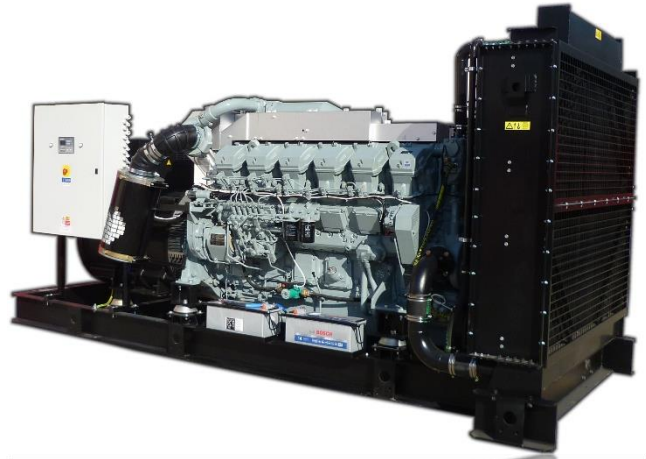

Output ratings

Prime power - PRP	1750 kVA / 1400 kW
Standby power - ESP	1900 kVA / 1520 kW
Current	2525 A
Voltage	400 V / 230 V
Frequency	50 Hz
Voltage system	TN-C

Prime power - PRP

These ratings are applicable for supplying continuous electrical power. There is no limitation to the hours of operation and this model can supply 10% overload power for 1 hour in 6 hours.

Standby power - ESP

These ratings are applicable for supplying continuous electrical power (at variable load) in the event of a utility power failure. No overload is permitted on these ratings. Maximum 500 operating hours per year are allowed with maximum continuous work for 300 hours.

Basic information

Engine brand	MITSUBISHI
Engine model	S16R-PTA
Emission limit	-
Speed	1500 min-1
Control panel current AMF5, M1, P1 (AMF1)	2500 A (- A)
Standard fuel tank capacity	1200 l

Dimensions and weights

Length (L)	5700 mm
Width (W)	2200 mm
Height (H)	2625 mm
Height with CP* (HCP)	
Weight without CP*	12780 kg
* Control panel	

Available alternators

Mecc Alte	ECO46-2S/4
Sincro	SK 450 LE
Marelli	MJB 450 LB 4
WEG	AG10 400 MI90HI



- TBD - To be defined later
- All pictures are for informational purposes only
- We reserve the right to change the specification without notice

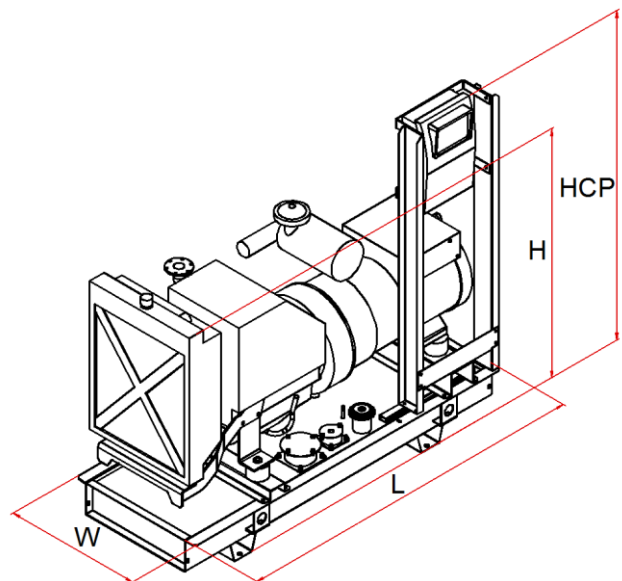

Genset details

Consumption @ 100% PRP	363 l
Consumption @ 75 % of PRP	272 l
Consumption @ 50 % of PRP	182 l
Consumption @ 25 % of PRP	91 l
Battery voltage	24 V
Battery	4 x 170 Ah

Standard scope of supply

Engine
4-stroke diesel engine
Engine harness
Radiator with fan
Air filter
Intercooler
Turbocharger (for turbocharged)
Charging alternator
Oil cooler
Oil filter
Fuel filter
Fuel supply pump
Oil draining valve
Starter
Alternator
Self regulation system
Self excitation system
Synchronous
Single bearing
Protection IP 21
Automatic voltage regulator
Brushless
Flexible connection disk + housing
Base frame
Steel base frame
Flexible antivibration mounting
Integrated fuel tank
Fuel level sensor
Fuel filling cap with ventilation
Starting accumulator
Counter flange, sealing, set of connection material
Initial filling of oil and coolant
Standard factory load test
Operation and maintenance manual

Engine details

Prime power - PRP	1450 kW
Standby power - ESP	1590 kW
Intake	turbocharged with intercooler
Speed governor	electronic
Cylinders	16V
Displacement	65,37 dm ³
Air requirement for intake	117 m ³ /min
Air requirement for cooling	1950 m ³ /min
Max. back-pressure at intake	4 kPa
Thermal power - cooling	854 kW
Thermal power - radiated	155 kW
Exhaust gas flow	309 m ³ /min
Max. back-pressure at exhaust	6 kPa
Max. exhaust temperature	539°C
Performance class	G 3
Specific fuel consumption	204 g/kWh
Engine oil volume	230 l
Coolant volume	380 l

Available optionals

Control panel	MP Manual
	MP Automatic
	MP Parallel
	MP ATS
Canopy 95LWA type [LWA / dB(A)]	100 / 75 @ 7 m
Canopy 90LWA type [LWA / dB(A)]	-
Container	40'
Industrial exhaust silencer -20 dB	DN 350
Residential exhaust silencer -30 dB	DN 350

Basic options

Retention bath	
Increased fuel tank	3000 l
Increased IP Protection	
Front air output for canopy	
Electronic speed governor	
Homologized chassis for road transport	
Separate storage tank	
Automatic fuel filling device (AFD)	

Many more other options available

Canopy - type 95 LWA

Side and back doors with lockers	
Side and/or back air inlet with jalousies	
Top air outlet	
Position of exhaust silencer	EN
Canopy colour: top RAL 3000 / bottom RAL 9005	
Length (L)	8804 mm
Width (W)	3064 mm
Height (H)	3705 mm
Height with industr. silencer (HI)	tlmič v kapote
Height with resid. silencer (HR)	tlmič v kapote
Weight without control panel and exhaust silencer	13 862 kg

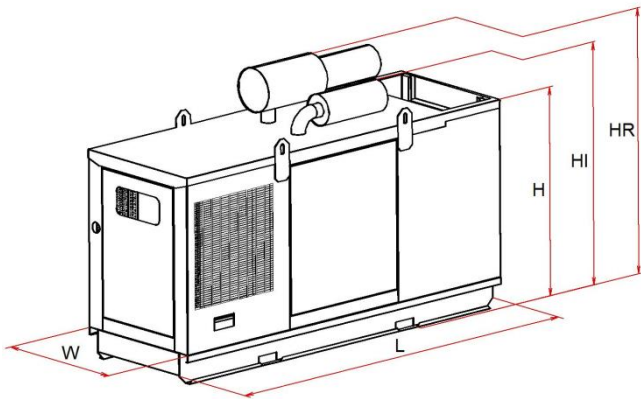

Canopy - type 90 LWA

Side and back doors with lockers	
Side and/or back air inlet with jalousies	
Top / side air outlet	
Canopy colour: top RAL 3000 / bottom RAL 9005	
Retention bath	
Exhaust silencer inside of canopy	
Length (L)	-
Width (W)	-
Height (H)	-
Weight without control panel and exhaust silencer	-

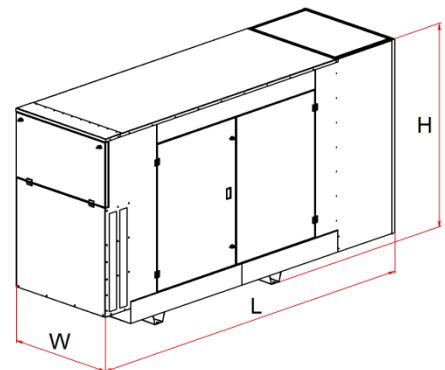

- TBD - To be defined later
- All pictures are for informational purposes only
- We reserve the right to change the specification without notice