



www. TTS-martin.sk

MARTIN POWER
MP 600 O-3
BASE GENSET



Output Ratings

Prime power - PRP	595 kVA / 476 kW
Standby power - ESP	657 kVA / 526 kW
Current	859 A
Voltage	400 V / 230 V
Frequency	50 Hz
Voltage system	TN-C

Prime power

These ratings are applicable for supplying continuous electrical power. There is no limitation to the hours of operation and this model can supply 10% overload power for 1 hour in 6 hours

Standby power

These ratings are applicable for supplying continuous electrical power (at variable load) in the event of a utility power failure. No overload is permitted on these ratings. In this rating max 500 hours per year is allowed with maximum continuous work for 300 hours

Basic informations

Engine brand	VOLVO
Engine model	TWD1652GE
Emmissions limit	stage IIIA
Speed	1500 min-1
Control panel current	- / 1000 A / 1000 A
AMF1 / AMF5 ,M1 ,P1 / ATS	
Standard fuel tank capacity	800 l

Dimmensions and weights

Length (L)	TBD
Width (W)	TBD
Height (H)	TBD
Height with CP*(HCP)	TBD
Weight without CP*	TBD

* Control panel

Available alternators

Meccalte	ECO40-1.5L/4
Sincro	SK 355 LS
Marelli	MJB 355 MA 4
Weg	315MI15AI



- TBD - To be defined later
- All pictures are for informational purposes only
- We reserve the right to change the specification without notice

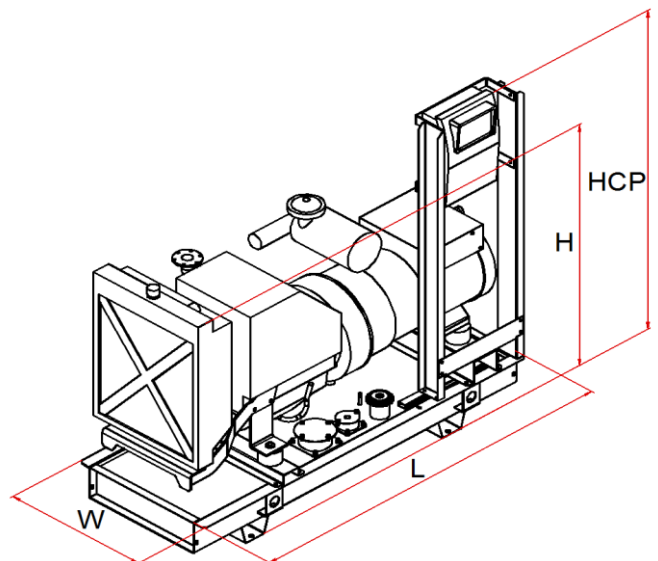

Genset details

Consumption at PRP	124,2 l
Consumption at 75 % of PRP	94 l
Consumption at 50 % of PRP	62,1 l
Consumption at 25 % of PRP	33,6 l
Battery voltage	24 V
Battery	2 x 140 Ah

Standard scope of supply

Engine	4 stroke diesel engine
	Engine harness
	Radiator with fan
	Air filter
	Intercooler
	Turbocharger (for turbocharged engines)
	Charging alternator
	Oil cooler
	Oil filter
	Fuel filter
	Fuel supply pump
	Oil draining valve
	Starter
Alternator	Self regulation system
	Self excitation system
	Synchronous
	Single bearing
	Protection IP 21
	Automatic voltage regulator
	Brushless
	Flexible connection disk + housing
Base frame	Steel base frame
	Flexible antivibration mounting
	Integrated fuel tank
	Fuel level sensor
	Fuel filling cap with ventilation
Starting accumulator	
Counter flange,sealing,set of coonnection material	
Initial filling of oil and coolant	
Standard factory load test	
Operation and maintenance manual	

Engine details

Prime power - PRP	505 kW
Standby power - ESP	557 kW
Intake	turbocharged with intercooler
Speed governor	electronic
Cylinders	6L
Displacement	16,12 dm ³
Air requirements for intake	40 m ³ /min
Air requirements for cooling	590 m ³ /min
Max. back pressure at intake	3 kPa
Thermic power - cooling	366 kW
Thermic power - irradiated	52 kW
Exhaust gas flow	105 m ³ /min
Max. back pressure at exhaust	10 kPa
Max. exhaust temperature	426 °C
Performance class	TBD
Specific fuel consumption	210 g/kWh
Engine oil volume	48 l
Coolant volume	166 l

Available additions

Control panel	MP Manual MP Automatic MP Parallel MP ATS
Canopy	95 LWA (70dB/7m) 90 LWA (65dB/7m)
Container	TBD
Industrial exhaust silencer -20 dB	DN 200
Residential exhaust silencer -30dB	DN 200

Basic options

Retention bath	
Increased fuel tank	2500 l
Increased IP Protection	
Front air output for canopy	
Electronic speed governor	
Homologized chassis for road transport	
Separate storage tank	
Automatic fuel filling device (AFD)	

Lot more options available

Canopy - 95 LWA (70 dB at 7 m)

Side and back doors with lockers

Side and/or back air inlet with jalousies

Top air outlet

Position of exhaust silencer in canopy

Red (RAL3000) + Black (RAL9005) color of canopy

Length (L) 4925 mm

Width (W) 2250 mm

Height (H) 2695 mm

Height with industr. silencer (HI) -

Height with resid. silencer(HR) -

Weight without control panel and exhaust silencer TBD

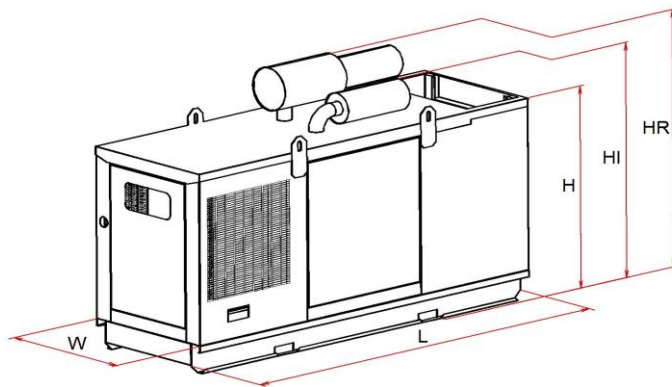
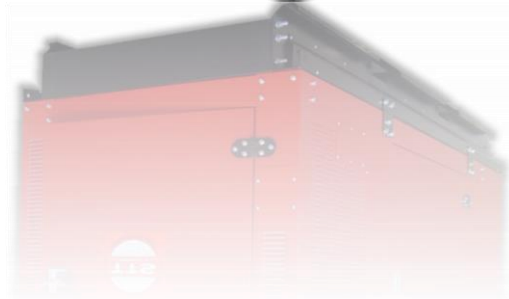

Canopy - 90 LWA (65 dB at 7 m)

Side and back doors with lockers

Side and/or back air inlet with jalousies

Top / side air outlet

Red (RAL3000) + Black (RAL9005) color of canopy

Retention bath

Exhaust silencer inside of canopy

Length (L) TBD

Width (W) TBD

Height (H) TBD

Weight without control panel and exhaust silencer TBD

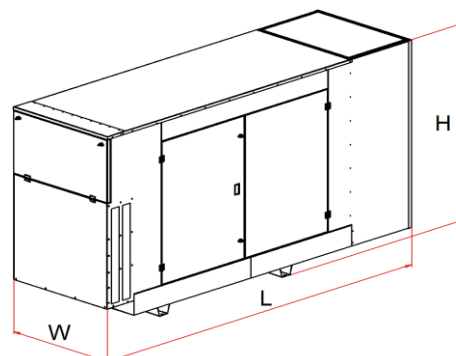

- TBD - To be defined later
- All pictures are for informational purposes only
- We reserve the right to change the specification without notice