



www.tts-martin.sk

MARTIN POWER MP 250 I



Output ratings

Prime power - PRP	250 kVA / 200 kW
Standby power - ESP	275 kVA / 220 kW
Current	361 A
Voltage	400 V / 230 V
Frequency	50 Hz
Voltage system	TN-C

Prime power - PRP

These ratings are applicable for supplying continuous electrical power. There is no limitation to the hours of operation and this model can supply 10% overload power for 1 hour in 6 hours.

Standby power - ESP

These ratings are applicable for supplying continuous electrical power (at variable load) in the event of a utility power failure. No overload is permitted on these ratings. Maximum 500 operating hours per year are allowed with maximum continuous work for 300 hours.

Basic information

Engine brand	FPT - IVECO
Engine model	N67 TE8W
Emission limit	-
Speed	1500 min-1
Control panel current AMF5, M1, P1 (AMF1)	400 A (- A)
Standard fuel tank capacity	500 l

Dimensions and weights

Length (L)	3080 mm
Width (W)	1315 mm
Height (H)	1740 mm
Height with CP* (HCP)	1740 mm
Weight without CP*	2438 kg

* Control panel

Available alternators

Mecc Alte	ECO38-1L/4
Sincro	SK 250 LS
Marelli	MJB 250 LB 4
WEG	AG10 250 SI20AI

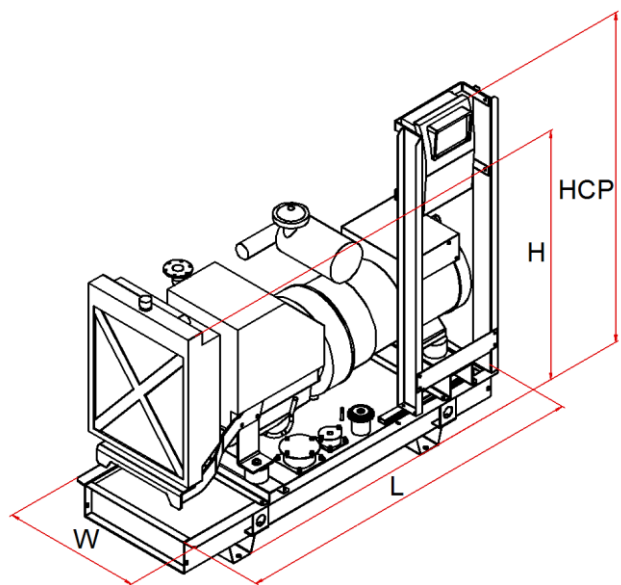

- TBD - To be defined later
- All pictures are for informational purposes only
- We reserve the right to change the specification without notice



Genset details

Consumption @ 100% PRP	56 l
Consumption @ 75 % of PRP	40 l
Consumption @ 50 % of PRP	29 l
Consumption @ 25 % of PRP	17 l
Battery voltage	24 V
Battery	2 x 140 Ah

Standard scope of supply

Engine
4-stroke diesel engine
Engine harness
Radiator with fan
Air filter
Intercooler
Turbocharger (for turbocharged)
Charging alternator
Oil cooler
Oil filter
Fuel filter
Fuel supply pump
Oil draining valve
Starter
Alternator
Self regulation system
Self excitation system
Synchronous
Single bearing
Protection IP 21
Automatic voltage regulator
Brushless
Flexible connection disk + housing
Base frame
Steel base frame
Flexible antivibration mounting
Integrated fuel tank
Fuel level sensor
Fuel filling cap with ventilation
Starting accumulator
Counter flange,sealing,set of coonection material
Initial filling of oil and coolant
Standard factory load test
Operation and maintenance manual

Engine details

Prime power - PRP	216 kW
Standby power - ESP	238 kW
Intake	turbocharged with intercooler
Speed governor	electronic
Cylinders	6L
Displacement	8,7 dm3
Air requirement for intake	20 m3/min
Air requirement for cooling	280 m3/min
Max. back-pressure at intake	5 kPa
Thermal power - cooling	130 kW
Thermal power - radiated	34 kW
Exhaust gas flow	34 m3/min
Max. back-pressure at exhaust	10 kPa
Max. exhaust temperature	488 °C
Performance class	G 3
Specific fuel consumption	196 g/kWh
Engine oil volume	28 l
Coolant volume	58 l

Available optionals

Control panel	MP Manual
	MP Automatic
	MP Parallel
	MP ATS
Canopy 95LWA type [LWA / dB(A)]	95 / 70 @ 7 m
Canopy 90LWA type [LWA / dB(A)]	90 / 65 @ 7 m
Container	20'
Industrial exhaust silencer -20 dB	DN 125
Residential exhaust silencer -30 dB	DN 125

Basic options

Retention bath	
Increased fuel tank	1500 l
Increased IP Protection	
Front air output for canopy	
Electronic speed governor	
Homologized chassis for road transport	
Separate storage tank	
Automatic fuel filling device (AFD)	

Many more other options available

Canopy - type 95 LWA

Side and back doors with lockers	
Side and/or back air inlet with jalousies	
Top air outlet	
Position of exhaust silencer	in the canopy
Canopy colour: top RAL 3000 / bottom RAL 9005	
Length (L)	3500 mm
Width (W)	1340 mm
Height (H)	2085 mm
Height with industr. silencer (HI)	-
Height with resid. silencer (HR)	-
Weight without control panel and exhaust silencer	2230 kg

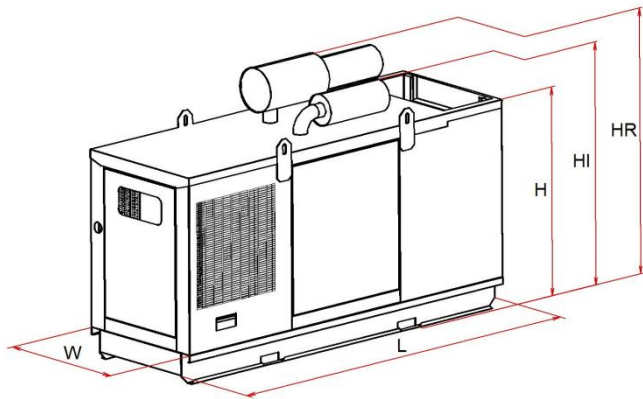
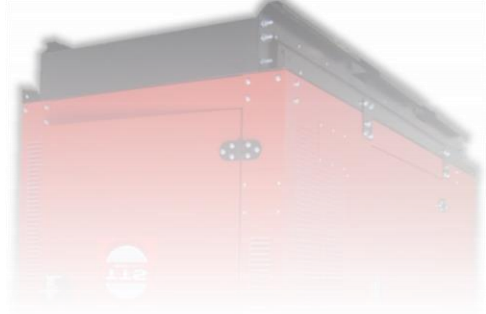

Canopy - type 90 LWA

Side and back doors with lockers	
Side and/or back air inlet with jalousies	
Top / side air outlet	
Canopy colour: top RAL 3000 / bottom RAL 9005	
Retention bath	
Exhaust silencer inside of canopy	
Length (L)	3650 mm
Width (W)	1100 mm
Height (H)	1900 mm
Weight without control panel and exhaust silencer	2291 kg

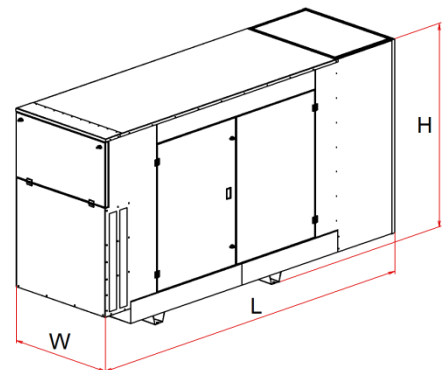

- TBD - To be defined later
- All pictures are for informational purposes only
- We reserve the right to change the specification without notice